

SLIK-73

SIMFACT II

- ▣ universal counter with batching function
- ▣ 2 pulse counting inputs
- ▣ 1 programmable function input
- ▣ 1 counter reset input
- ▣ 1 relay or OC output (option)



CE

The **SLIK-73** is a cross between the existing SLI-73 and SLK-73. The device has two independent counting inputs that can operate in various configurations. A programmable function input enables changing the operating mode of the counting inputs (up-down and down-up) or stopping the count. The **SLIK-73** counter features an independent reset input. It has 0 or 1 relay (or OC) output with programmable activation threshold, which can be used to control external equipment.

- digital, anti-disturbance filter,
- 4 counter reset sources,
- relay operation time programmable to 99 min.,
- programmable multiplier, divider and offset,
- programmable decimal point position,
- ACCESS option - easy threshold modification,
- RS-485 interface,
- available with AC and DC power supply versions.

Exemplary pin assignment

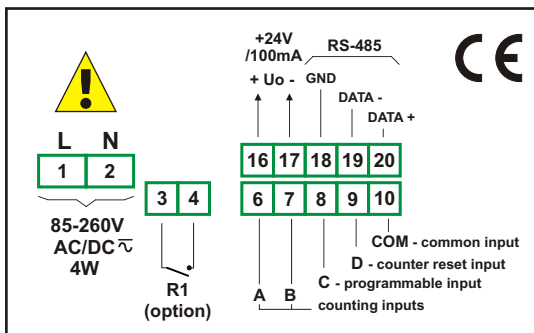

Ordering

SLIK-73-15XX-1-X-XX1

options:

- 00 : no options
- 01 : IP 65

power supply:

- 3 : 24V AC/DC
- 4 : 85V - 260V AC/DC

type of outputs:

- 0 : no output
- 1 : REL
- 2 : OC

number of outputs:

- 0
- 1

Typical applications

1. Counting current amount of manufactured items plus control of the production line.



Technical data

Power supply: 19V ± 50V DC; 16V ± 35V AC or 85 ± 260V AC/DC

Power consumption: for 85 ± 260V AC/DC and 16V ± 35V AC power supply: max. 4,5 VA; 19V ± 50V DC power supply: max. 4,5 W

Display: LED, red, 6 x 9 mm high

Inputs: pulse, galvanically isolated

- A and B inputs - counting (down-up and up-down or quadrature)
- C input - programmable
- D input - counter reset
- COM - common

Input levels: low: 0 V ± 1 V
high: 10 V ± 30 V (max. 12 mA for 24V)

Max. input frequency: electronic: 10 kHz
contact: max. 90 Hz (adjustable filter)

Displayed values range: from -99999 to 999999

Output: 0 or 1 relay 1A/250V AC (cosφ=1) or the OC 30mA/30VDC/100mW

Transducer power supply output: 24V DC +5%, -10% / max. 100 mA, stabilized, not insulated from communication interface

Communication interface: RS-485, 8N1 and 8N2, 1200 bit/s ± 115200 bit/s, Modbus RTU, not galvanically isolated from transducer power supply output

Data memory: non-volatile memory, EEPROM type

Operating temperature: 0°C ± +50°C

Storage temperature: -10°C ± +70°C

Protection class: IP 65 (front side when an additional frame is installed); IP 40 (front side); IP 20 (case and connection clips)

Case: board

Case material: NORYL - GFN2S E1

Case dimensions: 72 x 36 x 97 mm

Panel cut-out dimensions: 66,5 x 32,5 mm

Installation depth: min. 102 mm

Board thickness: max. 5 mm